

AM-AM and AM-PM Measurement of Baseband to RF Integrated Circuits for ACPR Calculations

Kevin Gard^{†‡}, Lawrence E. Larson[‡], and Michael B. Steer[§]

[†]QUALCOMM CDMA Technologies Inc., San Diego CA, [‡]Center for Wireless Communications, University of California San Diego, San Diego CA, [§]Department of Electrical and Computer Engineering, North Carolina State University, Raleigh NC

ABSTRACT

A method to measure the AM-AM and AM-PM characteristics of integrated circuits that operate with baseband inputs and RF outputs is presented. The technique requires control of the baseband input signal, three signal generators, and a vector voltage meter to make the measurement. ACPR calculated from the nonlinear transfer characteristic of two CDMA transmitter RFICs are compared with measured ACPR performance.

I. INTRODUCTION

Wireless integrated circuit technology is revolutionizing the digital cellular phone industry. The size and number of components required for a cell phone transceiver is shrinking mostly due to higher levels of RF circuit integration and implementation of direct conversion transceiver architectures. Nonlinear characterization of integrated circuits requires direct observation of the output signal. However, modern integrated transmitters upconvert baseband input signals to RF frequencies without providing convenient access to intermediate points to measure the RF signal. Traditionally, a vector network analyzer is used to characterize the complex gain transfer characteristic of devices with RF inputs and outputs; however, for baseband to RF devices other methods are needed since the input signal is at baseband.

This paper presents a simple technique for characterizing the AM-AM (amplitude-to-

amplitude) and AM-PM (amplitude-to-phase) characteristic of the output signal against a fixed reference signal is presented. The technique requires only a baseband input signal, three signal generators, and a two input vector voltage meter. The measurement technique is used to characterize the nonlinear gain and phase input output response of superheterodyne and direct conversion transmitter RFICs operating in the cellular and PCS frequency bands. Adjacent channel power rejection (ACPR) ratio for a CDMA signal is calculated using the measured nonlinear gain characteristics and compared against measured ACPR performance.

II. AM-AM AND AM-PM CHARACTERIZATION

The measurement set up consists of a vector voltmeter, reference generator, local oscillator and PLL reference generators, digital arbitrary waveform generator (D-ARB), eight-bit DAC, and a personal computer to provide waveforms to the D-ARB and control functions of the device under test (DUT). A block diagram of the measurement set up is shown in Figure 1. A measurement is made by comparing the RF output signal to a fixed reference signal while applying a DC offset to the DUT IQ modulator using the D-ARB and DAC. The input DC offset signal causes carrier feedthrough, of the local oscillator signal, which is proportional to the DC offset level. A vector voltmeter is used to compare the power and phase of the resulting

carrier signal relative to the fixed reference signal. A stable phase comparison measurement is achieved by phase locking the local oscillator and PLL reference generators to a reference output signal from the reference signal generator. The full range of the AM-AM and AM-PM characteristic is measured by recording the gain and phase comparison at each dc offset point. Measurement dynamic range is limited by the carrier suppression performance of the DUT I/Q modulator.

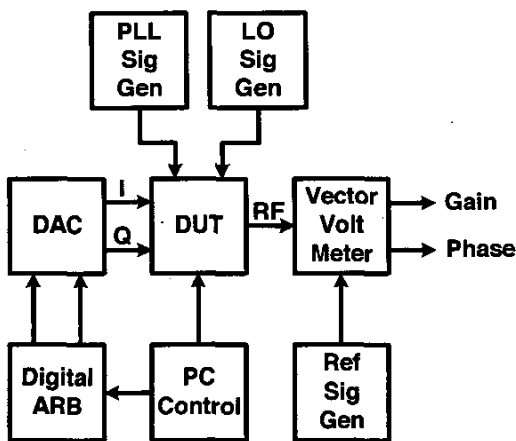

Figure 1: AM-AM, AM-PM Measurement setup.

III. MEASUREMENTS

The technique was used to measure the AM-AM and AM-PM characteristic of two CDMA transmitter RFICs. The first device under test is a dual band superheterodyne transmitter RFIC for CDMA/AMPS applications [1]. The transmitter contains an intermediate frequency (IF) I/Q modulator, IF variable gain amplifier (VGA) loaded by an external LC tank, followed by a single sideband (SSB) IF-RF upconverter, and an output driver amplifier. The transmitter provides over 90dB of gain control range and operates in the CELL and PCS frequency bands. The second device tested is a direct conversion transmitter RFIC for CDMA/AMPS applications [2]. The transmitter contains a baseband VGA, RF I/Q upconverter, RF VGA

loaded by on-chip LC tanks, and an output driver amplifier. The block diagrams of both transmitter RFICs are shown in Figure 2.

Both devices were measured by sweeping the input dc offset input from 0 dB to -40 dB relative to a full scale DAC input offset. The gain control input levels were set to provide 8 dBm and 10 dBm CDMA output power at CELL and PCS bands respectively. The resulting measured AM-AM and AM-PM curves of both devices are shown in Figure 3-6 for 836MHz and 1880MHz carrier frequencies. The apparent gain expansion exhibited by the direct conversion transmitter at low input signal levels is caused by the finite carrier suppression performance of the RF upconversion mixer. Carrier suppression of superheterodyne transmitter is improved over the direct conversion design due to the lower frequency of operation of the IF upconversion mixer.

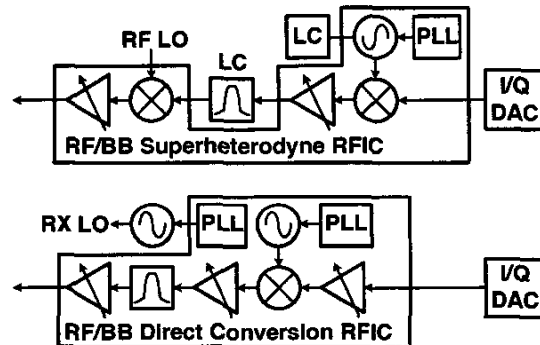

Figure 2: RFIC block diagrams.

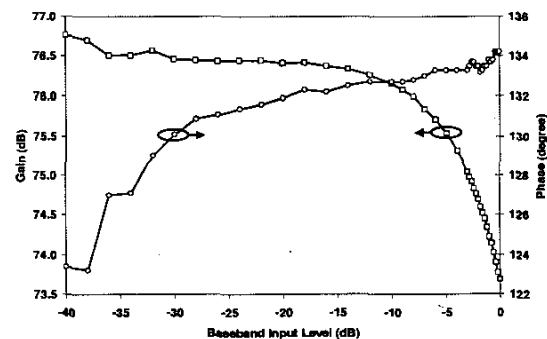

Figure 3: Measured superhet AM-AM, AM-PM at 836MHz.

IV. ACPR CALCULATION

The measured AM-AM and AM-PM characteristics were used to calculate ACPR from spectral regrowth simulations. A time domain calculation, based on a bandpass nonlinearity model, of the output spectrum versus input power was used to calculate ACPR from the measured characteristics [3], [4]. Calculated ACPR results are within 1 dB and 1.6 dB for CELL and PCS bands respectively for the first offset. Agreement for the second offset is within 2 dB for the superheterodyne transmitter, but there are significant deviations of 8.8 dB and 7.5 dB respectively for the direct conversion transmitter RFIC. The deviations are caused by false gain expansion due to carrier feedthrough at reduced baseband input signal levels. As a result, the predicted ACPR at the second offset is higher than measured because the gain characteristic appears nonlinear at lower input signal levels.

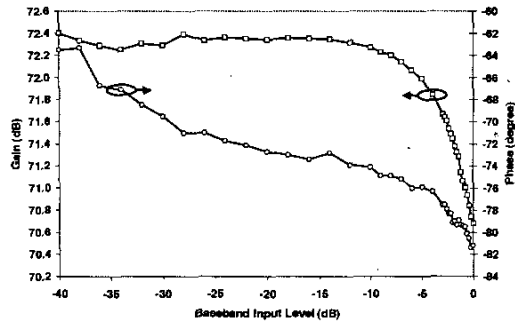

Figure 4: Measured superhet AM-AM, AM-PM at 1880MHz.

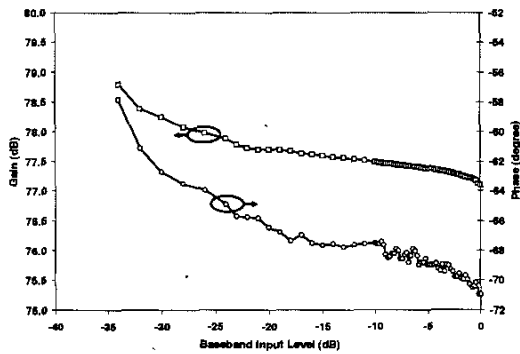

Figure 5: Measured direct conversion AM-AM, AM-PM at 836MHz.

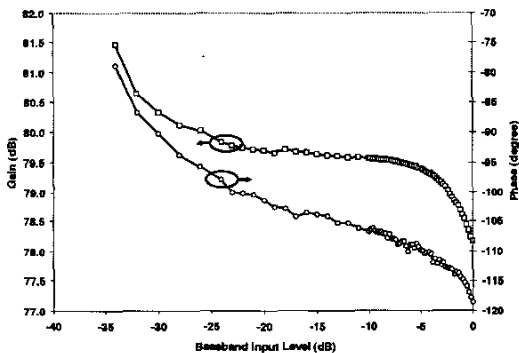

Figure 6: Measured direct conversion AM-AM, AM-PM at 1880MHz.

CELL 836MHz	Output Power dBm	ACPR 885kHz dBc/30kHz	ACPR 1.98MHz dBc/30kHz
Measured	8.3	52.2	71.8
Calculated	8.3	51.2	73.6
PCS 1880MHz	Output Power dBm	ACPR 1.25MHz dBc/30kHz	ACPR 1.98MHz dBc/30kHz
Measured	9.7	51.4	70.0
Calculated	9.7	52.9	69.8

Table 1: Measured and calculated ACPR for superheterodyne transmitter RFIC.

CELL 836MHz	Output Power dBm	ACPR 885kHz dBc/30kHz	ACPR 1.98MHz dBc/30kHz
Measured	8.0	59.2	76.6
Calculated	8.0	58.7	67.8
PCS 1880MHz	Output Power dBm	ACPR 1.25MHz dBc/30kHz	ACPR 1.98MHz dBc/30kHz
Measured	10.0	54.3	71.0
Calculated	10.0	52.7	63.5

Table 2: Measured and calculated ACPR for direct conversion transmitter RFIC.

V. CONCLUSIONS

A simple method for measuring the AM-AM and AM-PM characteristics of baseband to RF integrated circuits was presented. AM-AM and AM-PM measurements are made by using a vector voltmeter to compare the gain and phase of the output signal to a fixed reference signal. Three signal generators, digital arbitrary waveform generator, DAC, PC, and a vector voltmeter are all that is needed to make the AM-AM and AM-PM measurements. The technique can be used to characterize superheterodyne and direct conversion transmitter integrated circuits. ACPR calculations from measured AM-AM and AM-PM data for CELL and PCS bands are in excellent agreement with measured data.

ACKNOWLEDGEMENT

The authors would like to thank Brett Walker for providing the program for calculating CDMA ACPR from AM-AM and AM-PM data and Mua Tran for writing the automated test measurement code.

REFERENCES

- [1] K. Sahota, K. Gard, et al., "A Base-Band to RF BiCMOS Transmitter RFIC for Dual-Band CMDA/AMPS Wireless Handsets," *2000 IEEE Radio Frequency Integrated Circuits Symposium Digest*, pp. 129-132.
- [2] K. Gard, et al., "Direct Conversion Dual-Band SiGe BiCMOS Transmitter and Receive PLL for CDMA/WCDMA/AMPS/GPS Applications," *2003 IEEE Int. Solid-State Circuits Conf. Digest*, Feb. 2003, pp. 272-273.
- [3] S. W. Chen, W. Panton and R. Gilmore, "Effects of nonlinear distortion on CDMA communication systems", *IEEE Trans. Microwave Theor. Tech.*, Vol.44, Dec. 1996, pp. 2743-2749.
- [4] G. L. Heiter, "Characterization of Nonlinearities in Microwave Devices and Systems", *IEEE Trans. Microwave Theor. Tech.*, Vol.21, Dec. 1973, pp. 797-805.