

Strategies for Handling Complicated Device-Field Interactions in Microwave Systems

Michael B. Steer, Todd W. Nuteson, Christopher W. Hicks, James Harvey and James W. Mink

North Carolina State University

phone +1-919-846-3711; fax: 919-515-5523; email mbs@ncsu.edu

Device-field interactions are becoming increasingly important in RF, microwave and millimeter-wave systems. In many cases this is because cost minimization requires that microwave circuits be compressed to the point that coupling effects between different parts of a circuit can no longer be ignored. Sometimes, with large power devices or when operating at millimeter-wave frequencies and above, active device geometries become significant fractions of a wavelength so that the active device itself is a distributed element. A third type of device-field interaction occurs in active quasi-optical systems where a large array of devices spread over a distance of many wavelengths. The distinguishing characteristic of these quasi-optical systems is that signals are combined and interact in free-space, or in a dielectric, rather than being combined, manipulated, and guided by metallic interconnects. As such device-field interactions are integral parts of systems operation.

The only successful design methodology for obtaining high yielding, high performance microwave systems requires the use of computer aided engineering tools. The focus of this presentation is exploration of how systems involving strong device-field interactions can be incorporated in current microwave CAE technologies. We consider a number of strategies for modeling systems with strong device-field interaction with a focus on quasi-optical systems such as the grid amplifier system shown in Figure 1. A Method-of-Moments techniques is proposed for modeling that part of the circuit defined by the electromagnetic fields, and strategies for combining this model in transient analysis and harmonic balance engines is presented.

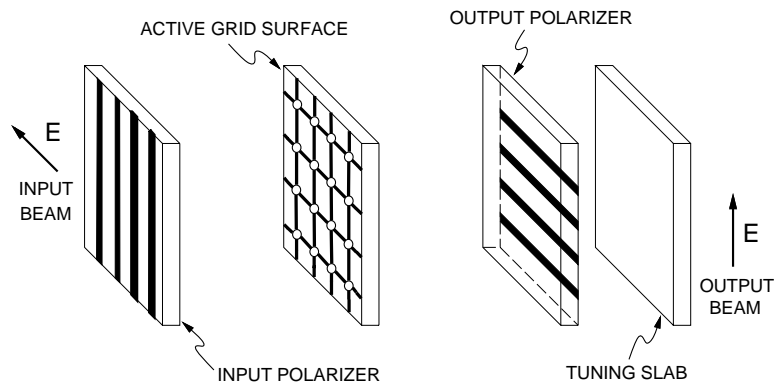

Figure 1: A quasi-optical grid amplifier with input and output polarizers.